



Type

Section

RENAULT Clio

X 57

X

42**42** UPPER CROSS MEMBER OF SPORTS GRILLEOther sub-section concerned: **41**• Engine: **XXX**• Gearbox: **XXX**

Basic manual

MR 296

There are two types of front end upper cross members for vehicles in the CLIO range:

(1) – For sports vehicles (C. 57D and C. 575): in 3 sections.

(2) – For all other types: in 1 section.

The design of the vehicle is such that the two side parts of the type (1) cross member can be cut from the type (2) cross member.

The central section of the cross member has a specific design (see the explanation in the Technical Note).

This means the Parts Department will supply:

- For type (2) vehicles: a front end assembly,
an upper cross member.
- For type (1) vehicles: a centre section of an upper cross member.

The side sections of the upper cross member and the front end assembly specific to type (1) can be cut from type (2) components.

LOWER STRUCTURE

Front end assembly

41

PART AS SUPPLIED BY THE PARTS DEPARTMENT

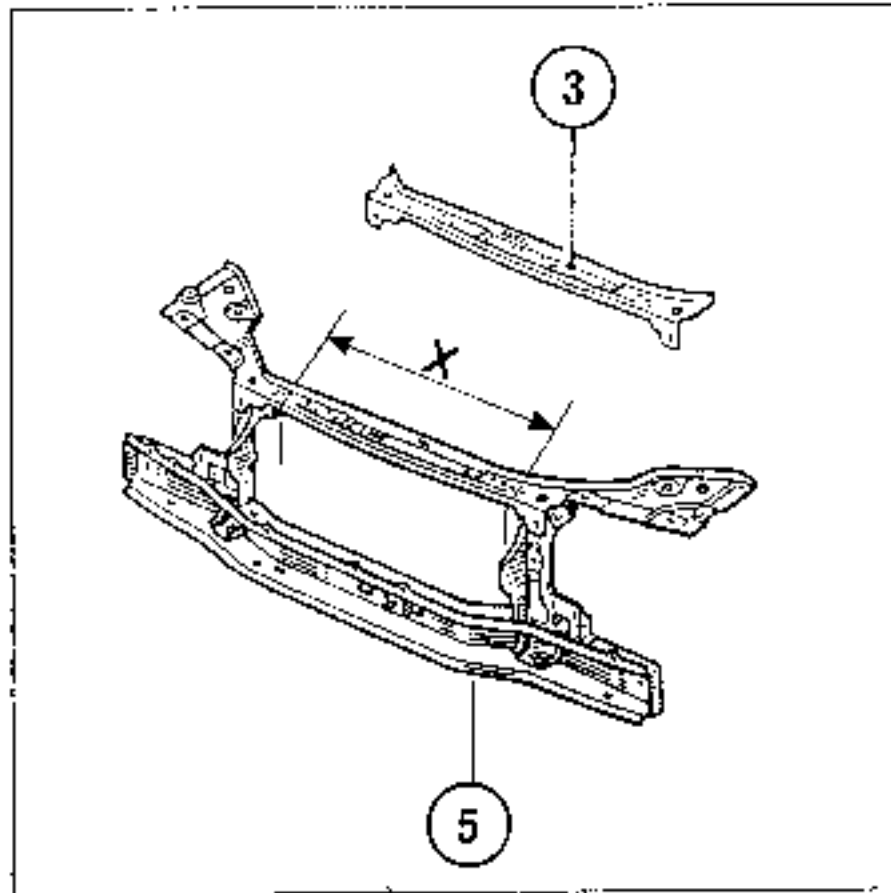

$X = 629$ mm (level with headlamp carrier panel)

The front end specifically for sports versions (C 57D and C 575) is no longer supplied by the Parts Department.

This must be cut out of the part above (5).

The section must be cut out after the cross member has been welded to the vehicle in order to ensure that the two side sections are correctly aligned.

Cross member (3), shown on the previous page, is positioned above the two side sections (1) and (2) as originally on the vehicle.

FRONT UPPER STRUCTURE

Front end upper cross member

42

PART AS SUPPLIED BY THE PARTS DEPARTMENT

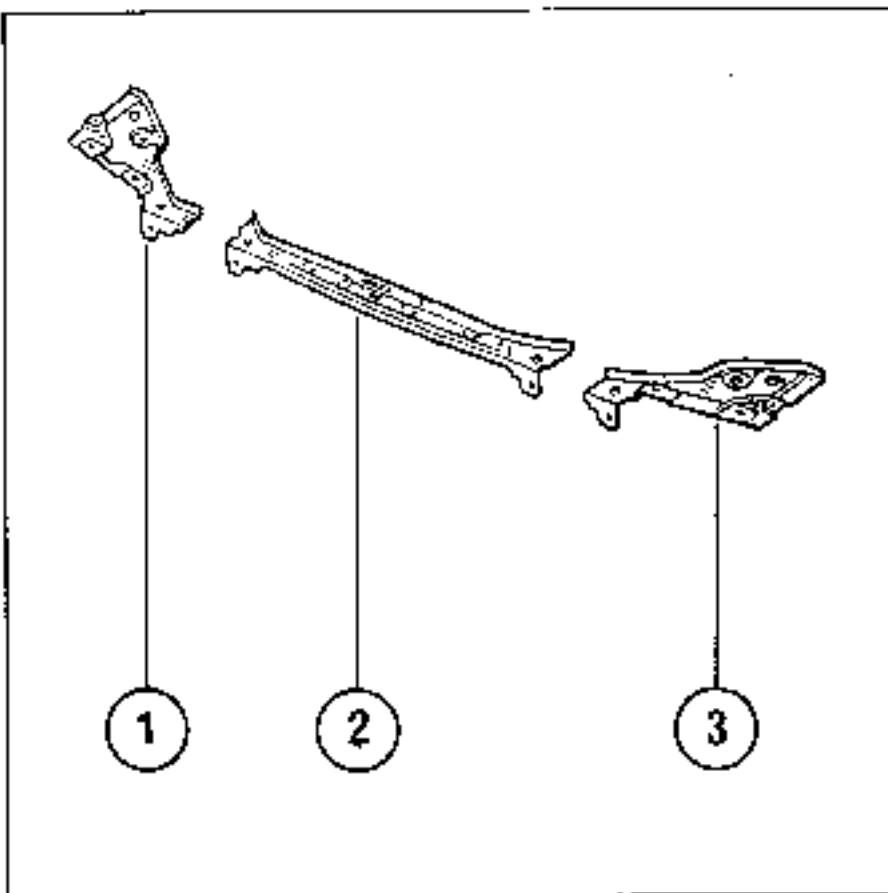

Parts (1) and (3) are no longer supplied by the Parts Department. These must be cut from part (4), as shown in the diagram opposite.

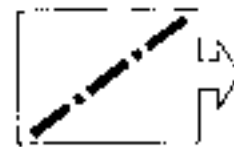
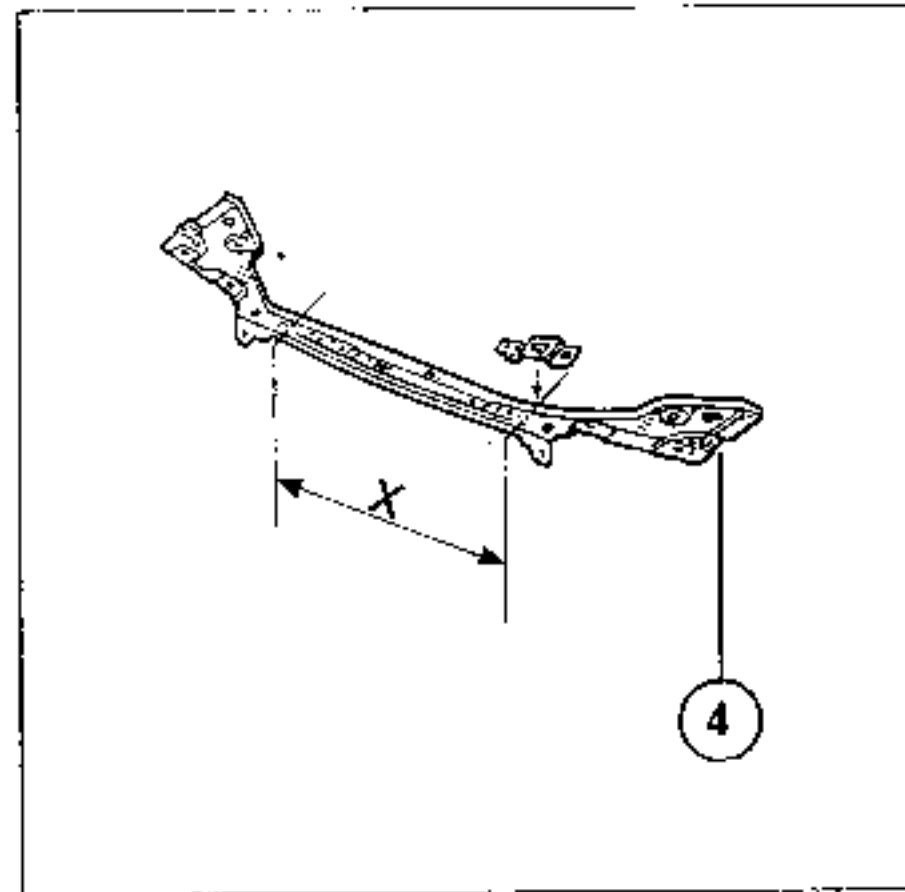

X = 620 mm

Note:

Part 2, which is specifically for the sports versions (C 57D and C 575), is still available.

The cutting operation must be performed after the cross member has been welded on to the vehicle, in order to ensure that the two side sections are correctly aligned.