



Clio

Type

S/Section

X57 K

62

62

Other sub-section concerned :

07

16

19

- Engine : D7F
 - Gearbox : XXX
- Basic manual : N.T. 2466

This technical note deals with the special features of the Clio equipped with the D7F engine fitted with air conditioning.

Summary

	Pages
07 SETTING AND ADJUSTMENT VALUES	
Accessories belt tension	07-1
16 STARTING - CHARGING	
Alternator	16-1
19 COOLING SYSTEM	
Refilling and bleeding	19-1
Wiring diagram	19-2
Radiator	19-3
62 AIR CONDITIONING	
General	62-1
Compressor	62-2
Connection pipes	62-3
Evaporator	62-7
Condenser	62-10
Pressure relief valve	62-12
Temperature sensor	62-13
Air recycling motor	62-14
Dehydrating bottle	62-15
Three-way pressure switch	62-16
Electronic unit	62-17
Passenger compartment fan	62-18

"The repair methods given by the manufacturer in this document are based on the technical specifications current when it was prepared.

The methods may be modified as a result of changes by the manufacturer in the production of the various component units and accessories from which his vehicles are constructed".

All copyrights reserved by Renault.

Copying or translating, in part or in full, of this document or use of the service part reference numbering system is forbidden without the prior written authority of RENAULT.

SETTING AND ADJUSTMENT VALUES

Accessories belt tension

07

ESSENTIAL SPECIAL TOOLING

Mot. 1273 Tool for checking belt tension

INSTRUCTIONS FOR TENSIONING

With the engine cold (ambient temperature), fit the new belt.

Fit the sensor of tool **Mot. 1273** onto the point marked (→).

Turn the wheel of the sensor until it "clicks".

Tension the belt until the recommended fitting value is obtained on the display of tool **Mot. 1273**.

Lock the tensioner, carry out a check and adjust the value if necessary.

Turn the crankshaft three turns.

Carry out a check and if necessary adjust to the fitting tension.

Never refit a belt that has been removed; fit a new belt.

Tension (US = SEEM units)	Multi-toothed alternator belt	AC compressor multi-toothed belt
Fitting tension	102 ± 7	107 ± 7
Minimum operating tension	53	56

Alternator belt

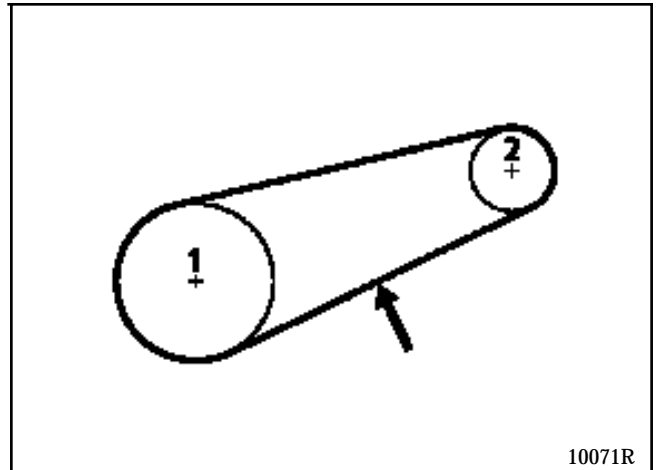

10071R

- 1 Crankshaft
- 2 Alternator
- Tension checking point

Compressor belt

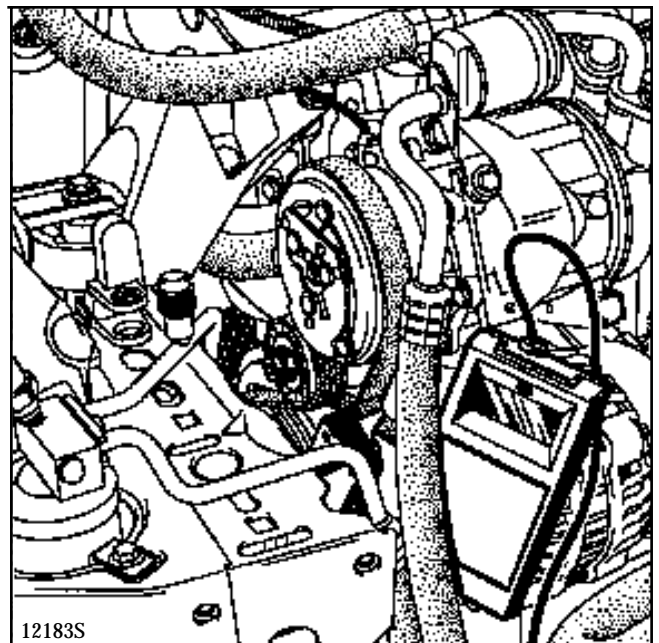

12183S

ESSENTIAL SPECIAL TOOLING

Mot. 1273 Tool for checking belt tension

REMOVAL

Place the vehicle on a two-post lift.

Disconnect the battery.

Remove :

- the bonnet,
- the righthand wheel arch trim,

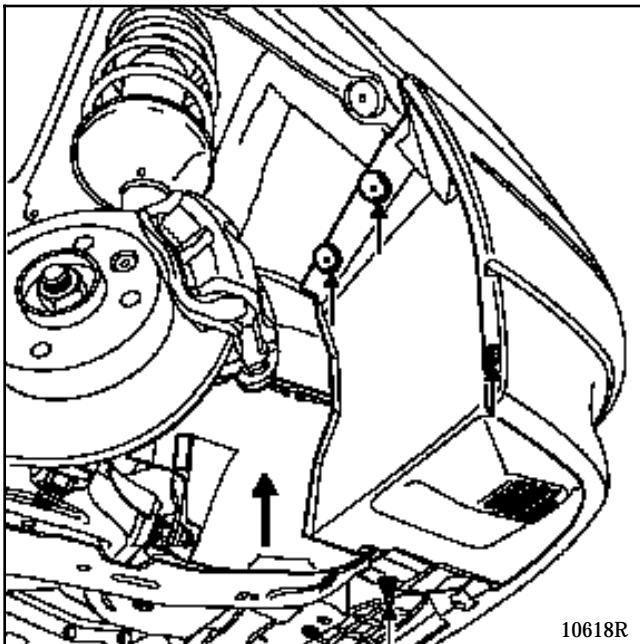

- the compressor belt and the alternator belt,
- the electrical connections from the alternator,
- the alternator mountings and separate it,
- the alternator support bracket.

Remove the alternator from underneath the vehicle (between the engine and the engine cradle).

REFITTING (special points)

Refitting is carried out in reverse order to removal.

The alternator belt is tensioned using a locally manufactured tool (threaded pin length **100 mm** (X) and three **M6** nuts).

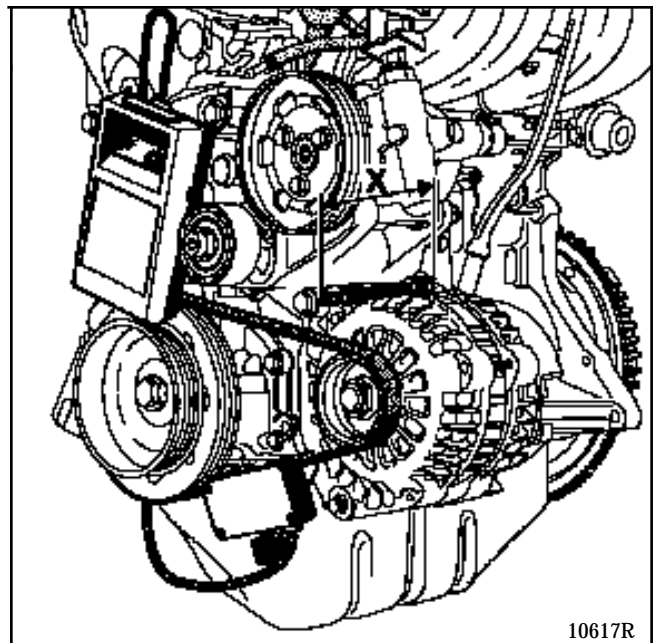

Refer to section **07** relating to "**Tensioning the accessories belt**" for the tensioning values for the compressor belt and the alternator belt.

There is no plug for the heater unit.

Circulation in the heater unit is continuous and contributes towards the engine cooling circuit.

REFILLING

Check the tightness of the drain plug(s).

Undo the two bleed screws.

Refill the circuit via the expansion bottle aperture.

Close the bleed screws as soon as the liquid runs out as a continuous flow.

Start the engine (**2 500 rpm**).

Top up the level to overflowing for approximately **4 minutes**.

Re-seal the expansion bottle reservoir.

BLEEDING

Leave the engine running for **10 minutes** at **2 500 rpm**, until the engine cooling fan cuts in (time needed for automatic degassing).

Check that the level of the liquid is close to the "**Maximum**" mark.



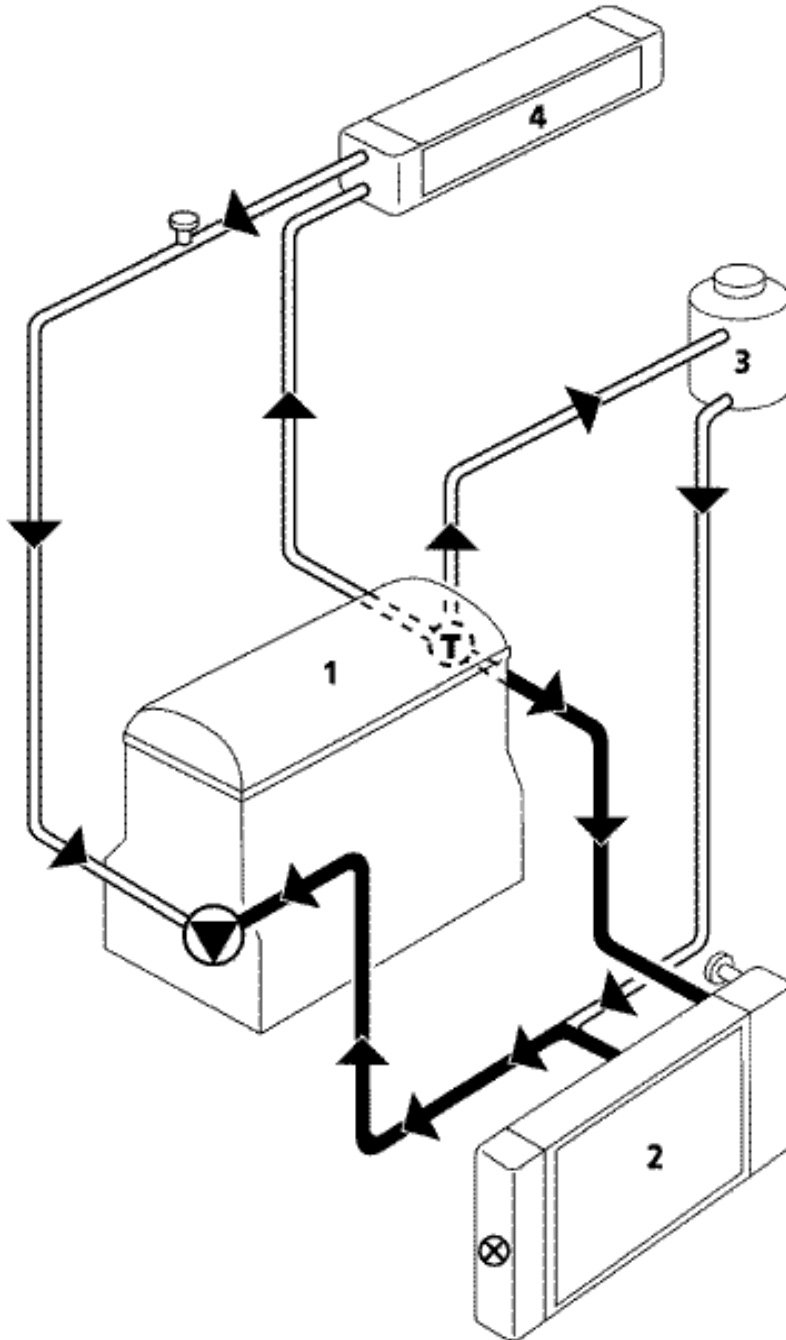

DO NOT UNDO THE BLEED SCREW(S) WHILST THE ENGINE IS RUNNING.

RE-TIGHTEN THE EXPANSION BOTTLE CAP WHEN THE ENGINE IS HOT.



10070-1R

- 1 Engine
- 2 Radiator
- 3 "Hot" reservoir bottle with permanent degassing
- 4 Heater unit

-  Water pump
-  Thermostat
-  Bleed screws
-  Thermocontact

The expansion bottle valve is coloured blue; the valve calibration is 1.2 bar.

REMOVAL

Place the vehicle on a two-post lift.

Disconnect the battery.

Drain the cooling circuit via the water pump hose.

Remove :

- the bonnet,
- the left and righthand wheel arch trims,

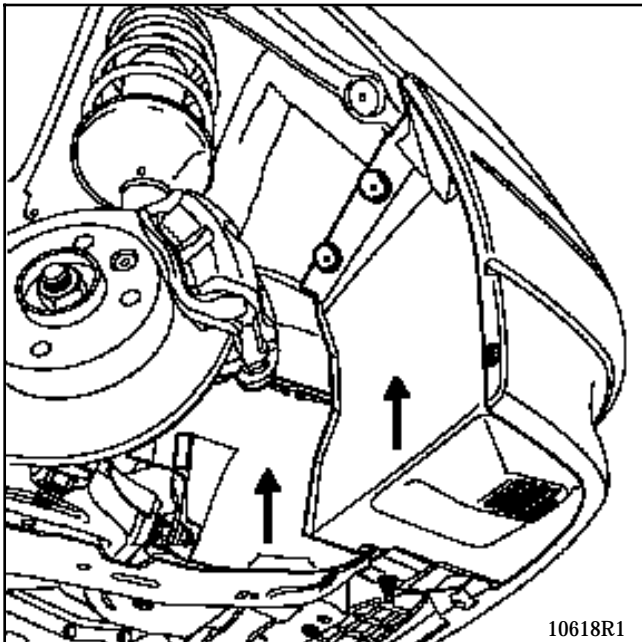

- the front bumper.

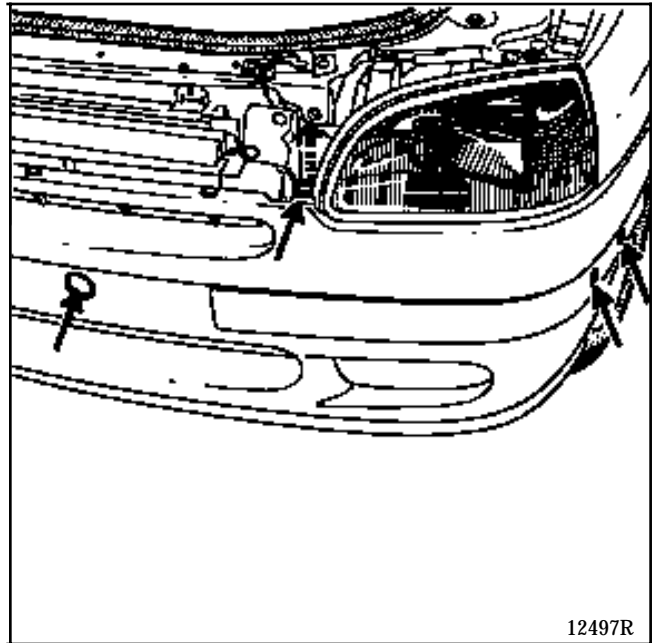

Disconnect:

- the upper hose from the radiator and the lower hose from the expansion bottle,
- the cooling fan connectors, relays, the thermostat and the three-way pressostat.

- the three mountings securing the dehydrating bottle to the radiator,
- the radiator upper mounting bolts (1),
- the mountings securing the condenser to the radiator (2).

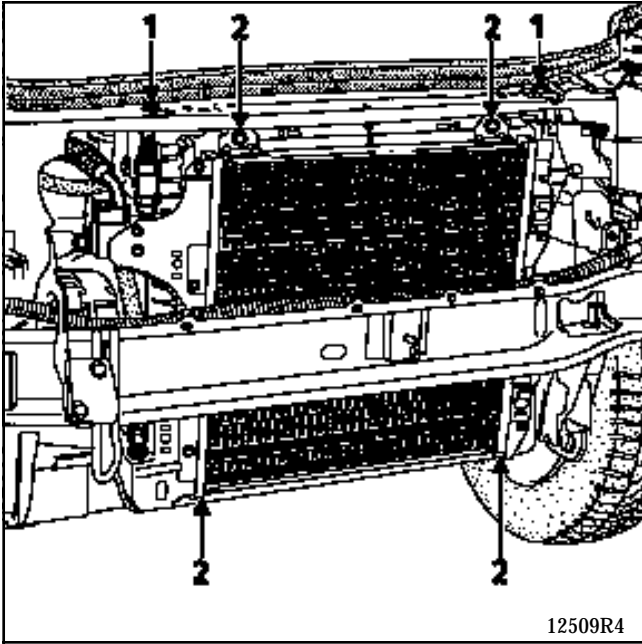

12509R4

Lift the cooling assembly so as to disengage the radiator lugs from the lower cross member.

Move the assembly sufficiently forwards so as to remove the lower mountings securing the condenser to the radiator (3).

Take out the radiator **taking special care not to damage the condenser fins.**

REFITTING

Refit in reverse order to removal.

Refill and bleed the cooling circuit (see section 19 relating to "**Refilling and bleeding**").

CONSUMABLES

	Oil for variable cubic capacity compressor	Refrigerant fluid
Type	SANDEN SP10 (PAG)	R134a
Quantity	135 cm ³	660 g ± 35

REMOVAL

To carry out this operation, the refrigerant circuit must be drained.

Disconnect the battery

Slacken off the tensioner pulley and remove the belt.

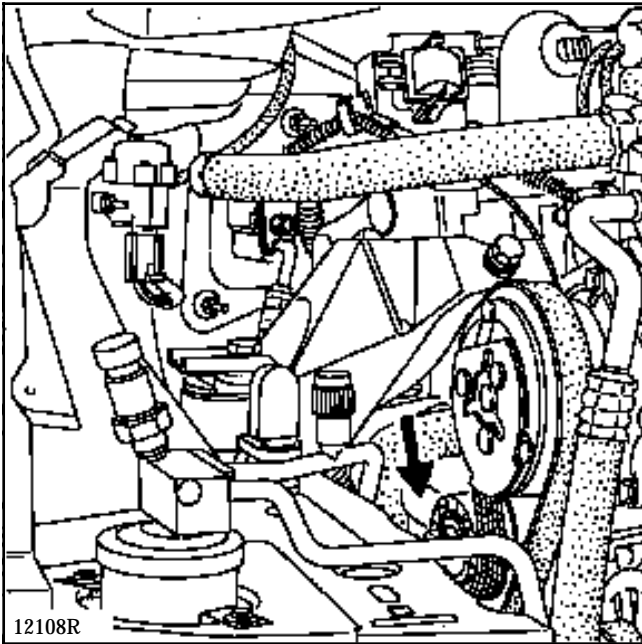

Remove :

- the bolt securing the high pressure pipe,
- the bolt securing the low pressure pipe.

Fit the plugs in the holes.

Disconnect the compressor clutch feed.

Remove :

- the compressor flange bolt (1),
- the compressor mounting bolts (3).

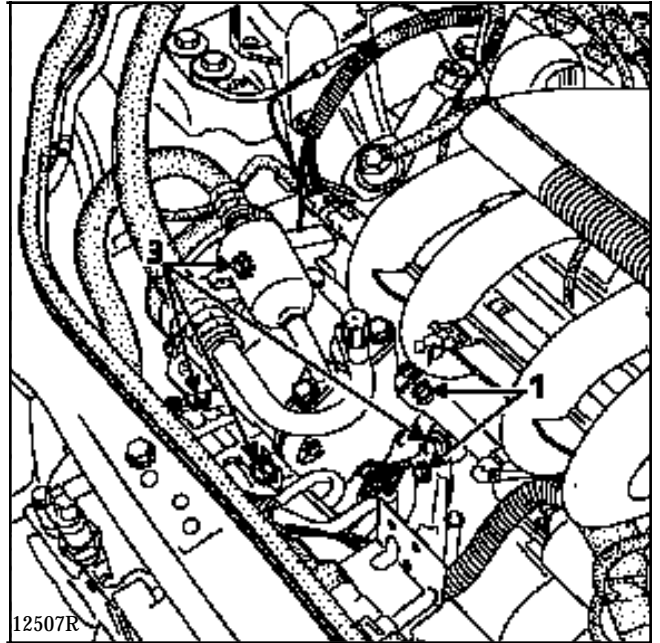

Take the compressor out from above.

REFITTING

Refitting is carried out in reverse order to removal.

TIGHTENING TORQUES (in daN.m)



Bolts securing pipes to the compressor	2
Bolts securing the compressor to its support	3

When fitting the pipes to the various components, the joints must be oiled using **SP10** type oil .

Fill the circuit with refrigerant fluid using the charging station.

Refit the belt and check the belt tension referring to the method described in section **07** entitled "**Accessories belt tension**".

IMPORTANT : The instructions relating to topping up with oil must be strictly observed when carrying out an operation on any of the components in the air conditioning circuit.

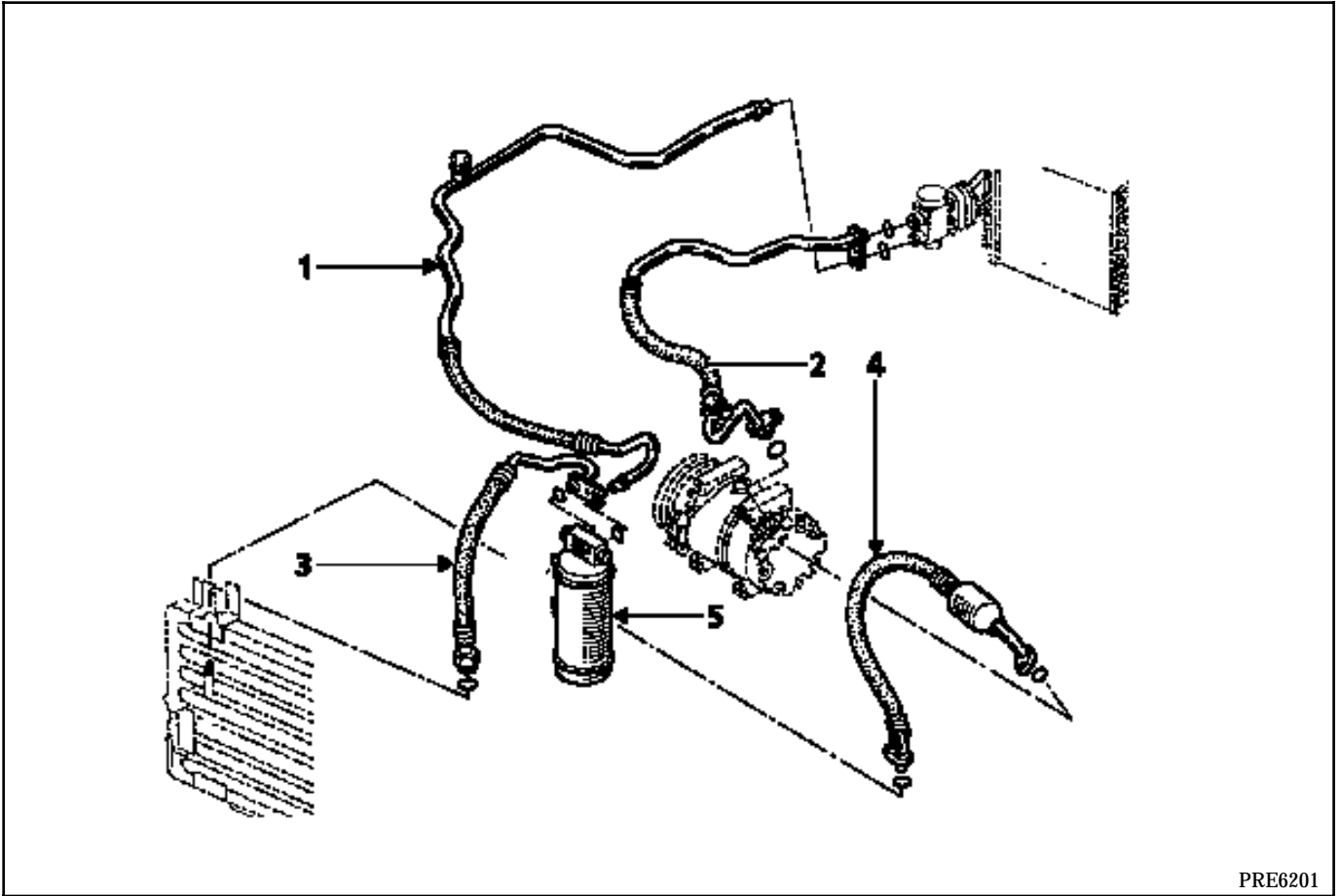

PRE6201

- 1 Pipe between the dehydrating bottle and the pressure relief valve
- 2 Pipe between the compressor and the pressure relief valve
- 3 Pipe between the dehydrating bottle and the condenser
- 4 Pipe between the dehydrating bottle and the compressor
- 5 Dehydrating bottle

TIGHTENING TORQUES (in daN.m)	
Flange bolt for pressure relief valve pipes	1
Flange bolt for dehydrating bottle pipes	1
Bolts for condenser pipe	2
Nuts for condenser pipe	2
Bolts for pressure relief valve pipe on compressor	2
Bolts for condenser pipe on compressor	2

PIPE (1) BETWEEN THE DEHYDRATING BOTTLE AND THE PRESSURE RELIEF VALVE

REMOVAL

Drain the **R134a** refrigerant circuit using the charging station.

Disconnect the battery.

Unclip at (A).

Remove :

- the clip securing the pipe located above the righthand front headlight,
- the flange bolt for the pressure relief valve pipes ,
- the flange bolt for the dehydrating bottle pipes.

Release the pressure relief valve pipe to the compressor and remove the pipe (1).

Fit the plugs in the holes.

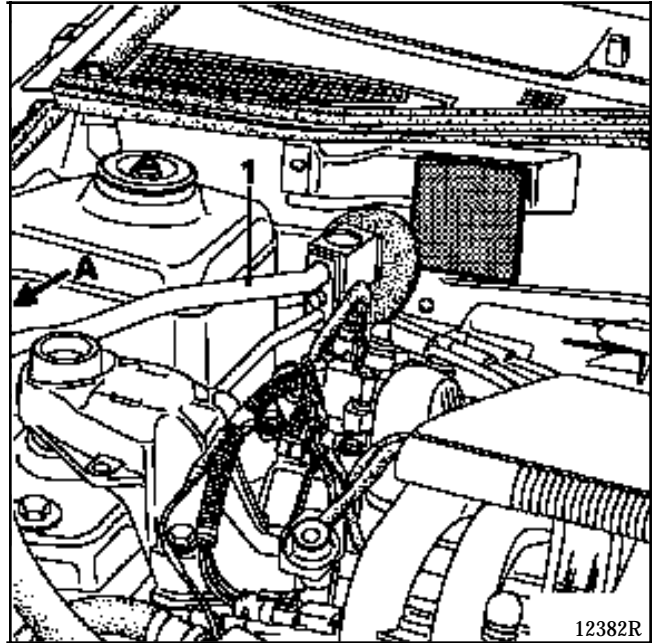

REFITTING

Refit in reverse order to removal. Refit and oil the joints using **SP10** oil and tighten to the recommended tightening torque.

When replacing a pipe, add **10 ml** of **SP10** oil or if a pipe is split (rapid leakage), add **100 ml** and change the dehydrating bottle.

PIPE (2) BETWEEN THE COMPRESSOR AND THE PRESSURE RELIEF VALVE

REMOVAL

Drain the **R134a** refrigerant circuit using the charging station.

Disconnect the battery.

Unclip at (A).

Remove :

- the bolt for the compressor pipe,
- the flange bolt for the pressure relief valve pipes ,
- the pipe and fit the plugs in the holes.

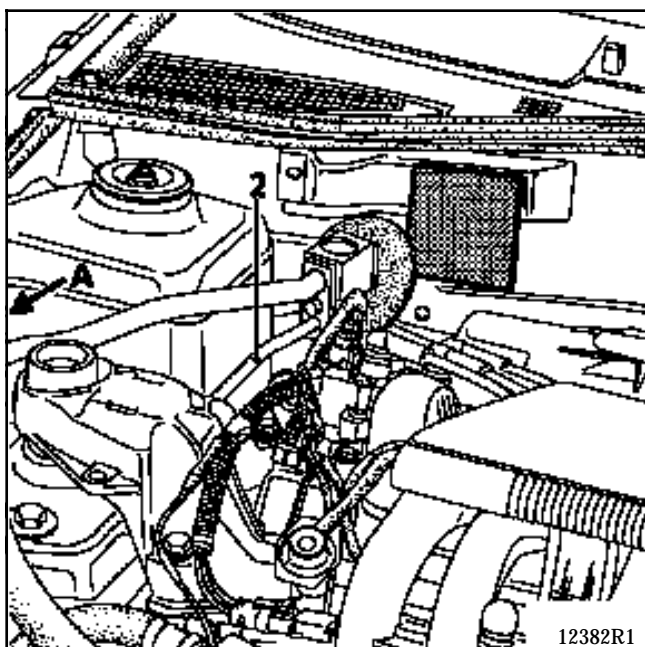

REFITTING

Refit in reverse order to removal. Refit and oil the joints using **SP10** oil and tighten to the recommended tightening torque.

When replacing a pipe, add **10 ml** of **SP10** oil or if a pipe is split (rapid leakage), add **100 ml** and change the dehydrating bottle.

PIPE (3) BETWEEN THE CONDENSER AND THE DEHYDRATING BOTTLE

REMOVAL

Place the vehicle on a two-post lift.

Drain the **R134a** refrigerant circuit using the charging station.

Disconnect the battery.

Remove :

- the flange bolt for the dehydrating bottle pipes ,
- the condenser pipe (accessible from underneath the vehicle) and fit the plugs in the holes.

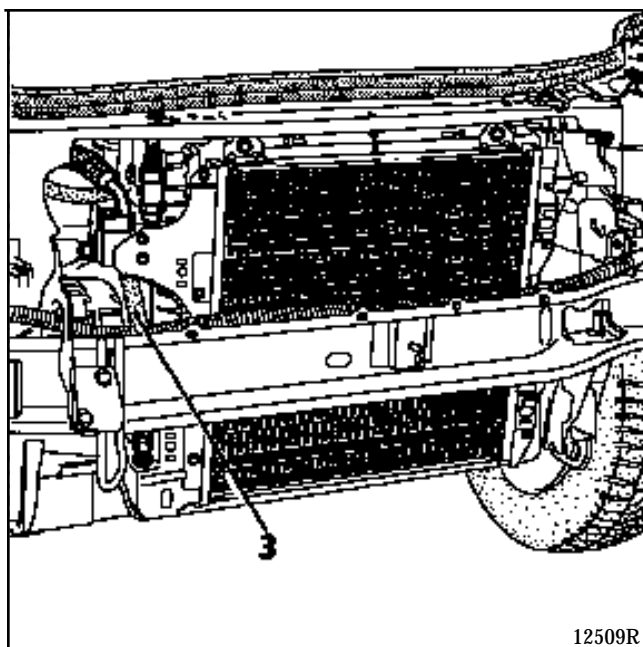

REFITTING

Refit in reverse order to removal. Refit and oil the joints using **SP10** oil and tighten to the recommended tightening torque.

When replacing a pipe, add **10 ml** of **SP10** oil or if a pipe is split (rapid leakage), add **100 ml** and change the dehydrating bottle.

PIPE (4) FOR THE CONDENSER ON THE COMPRESSOR

REMOVAL

Drain the **R134a** refrigerant circuit using the charging station.

Disconnect the battery.

Remove :

- the bolt for the compressor pipe,
- the bolt for the condenser pipe
- the pipe and fit the plugs in the holes.

REFITTING

Refit in reverse order to removal. Refit and oil the joints using **SP10** oil and tighten to the recommended tightening torque.

When replacing a pipe, add **10 ml** of **SP10** oil or if a pipe is split (rapid leakage), add **100 ml** and change the dehydrating bottle.

TIGHTENING TORQUES (in daN.m)



Flange bolt for pressure relief valve pipes	1
Bolts for pressure relief valve	2

REMOVAL

Drain the **R134a** refrigerant circuit using the charging station.

Disconnect the battery.

Remove :

- the windscreen wiper arms,
- the external air intake grilles,
- the bolt for the heat shield to make it easier to remove the heater bulkhead closing panel at (1).

Unclip at (A).

Remove :

- the clip for the pipe located above the front righthand headlight,
- the flange bolt for the pressure relief valve pipes and disengage the pipes. Fit the plugs in the holes,

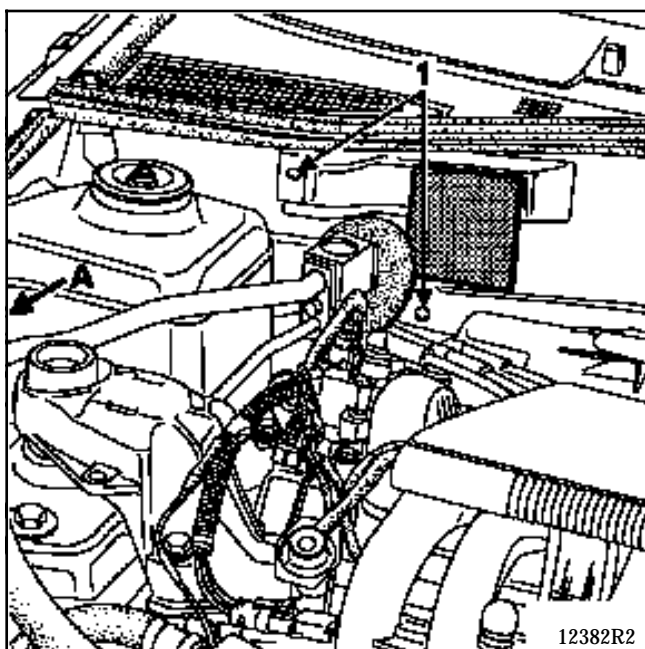

- the earth wiring braid on the bulkhead.

Disconnect the electrical wiring.

Remove :

- the air duct by removing the two bolts at (C),
- the drainage support fitted beneath the windscreen surround.

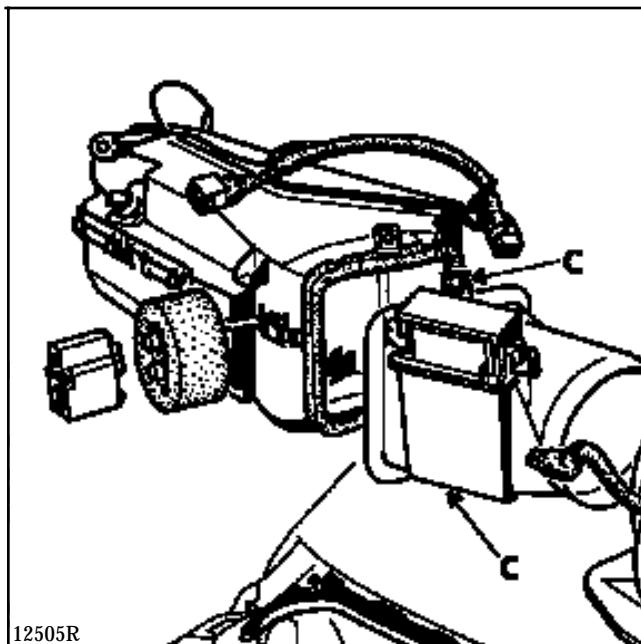

REMOVAL

Remove :

- the top of the dashboard and release the electrical wiring at (D),
- the right and lefthand side dashboard bolts at (E) to make it easier to remove the evaporator assembly nut and bolt.

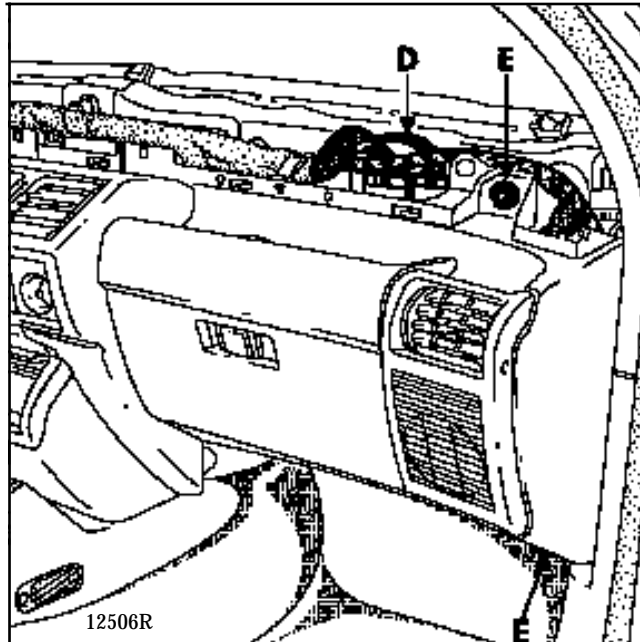

Gently pull on the dashboard (taking care not to damage it) and remove the nut and bolt for the evaporator assembly.

NOTE : Gain access to the evaporator assembly nut and bolt from underneath the dashboard.

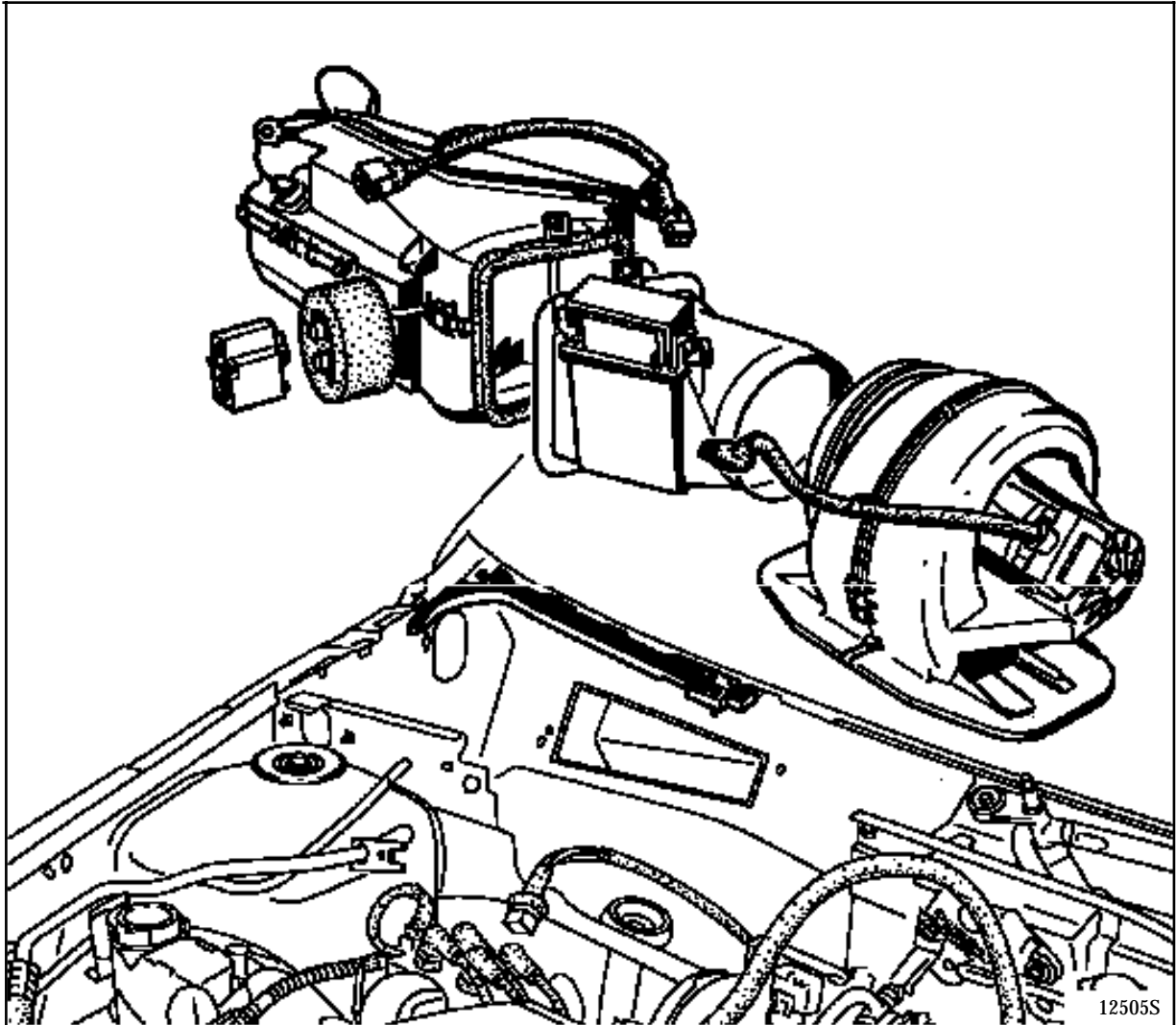

REFITTING

Refit in reverse order to removal. Refit and oil the joints using **SP10** oil and tighten to the recommend tightening torque.

When replacing a pipe, add **10 ml** of **SP10** oil or if a pipe is split (rapid leakage), add **100 ml** and change the dehydrating bottle.

TIGHTENING TORQUES (in daN.m)



Pressostat	1
Bolt for condenser pipe	2
Nuts for condenser pipe	2

REMOVAL

Place the vehicle on a two-post lift.

Drain the **R134a** refrigerant circuit using the charging station.

Disconnect the battery.

Remove :

- the wheel arch trim, nuts and bolts (A),

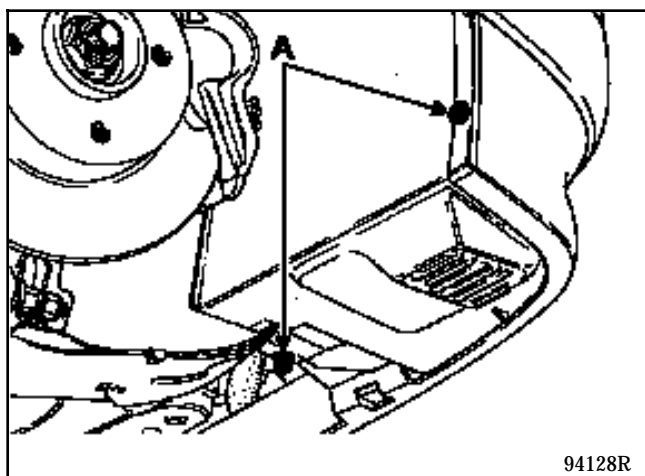

94128R

- the bumper,

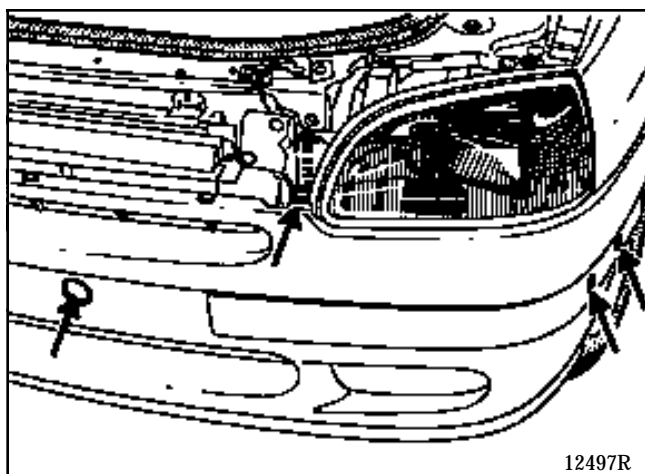

12497R

- the deflectors.

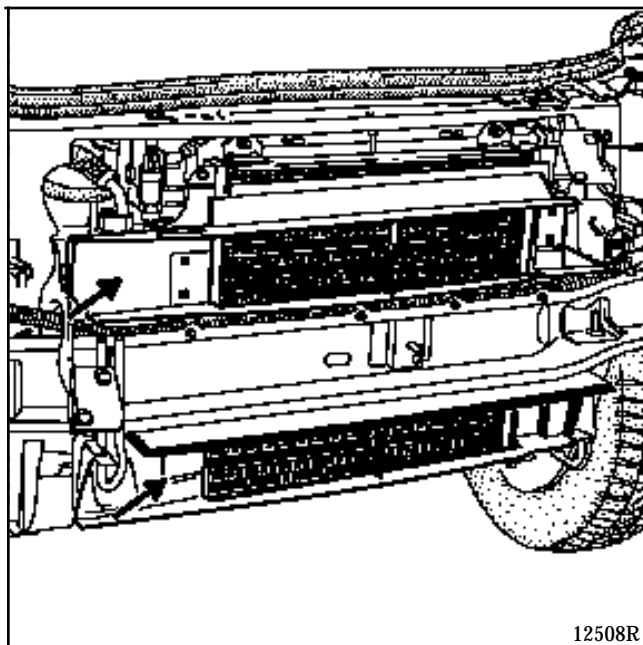

12508R

Disconnect the pressostat.

Remove :

- pipe (B) and fit a plug in the hole,
- the mountings for the radiator.

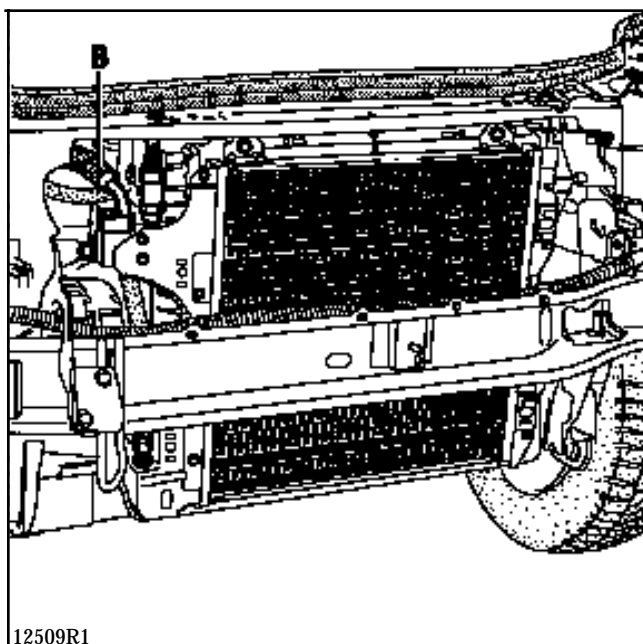

12509R1

Strip the radiator, fit a small wedge at (D) and remove the two nuts and bolts for the condenser and then rebuild the radiator.

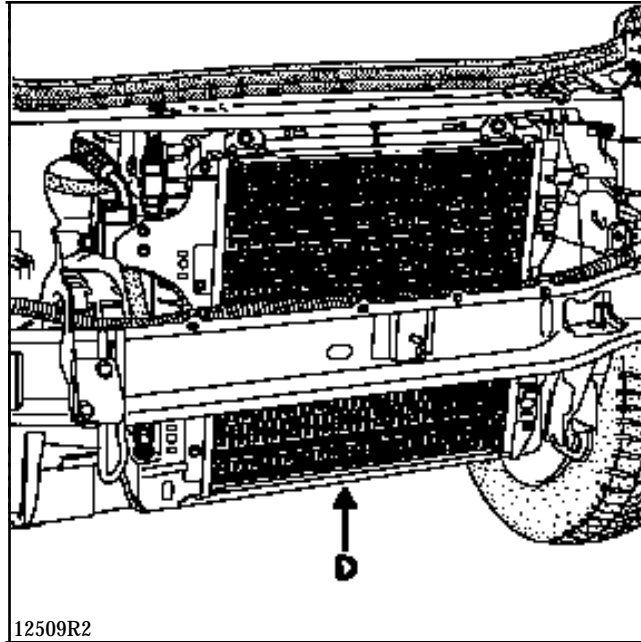

Remove the upper nuts and bolts from the condenser and remove it from below.

REFITTING

Refit in reverse order to removal.

TIGHTEN ALL THE NUTS AND BOLTS TO THE RECOMMENDED TIGHTENING TORQUES.

TIGHTENING TORQUES (in daN.m)	
Flange bolt for pressure relief valve pipes	1
Pressure relief valve bolt	1

REMOVAL

Drain the **R134a** refrigerant circuit using the charging station.

Disconnect the battery.

Unclip at (A).

Remove :

- the clip securing the pipe, located above the front righthand headlight,
- the flange bolt for the pressure relief valve, disengage the pipes and fit the plugs in the holes,
- the pressure relief valve mounting bolts.

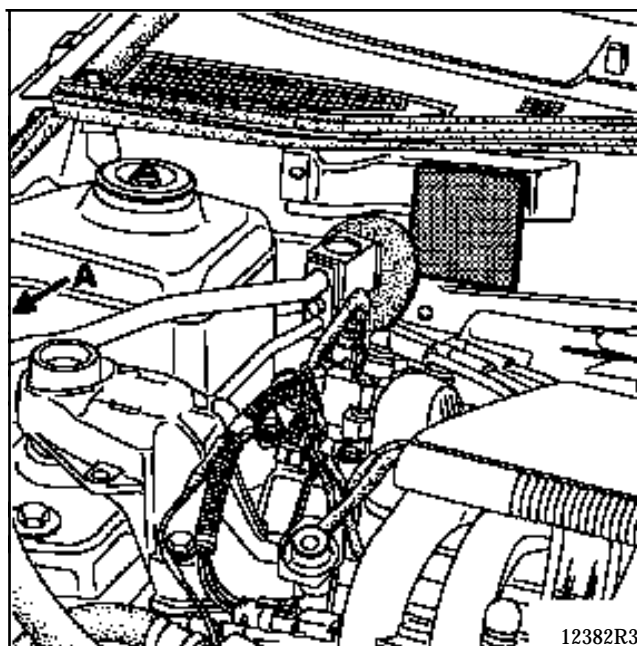

REFITTING

Refit in reverse order to removal. Refit and oil the joints using **SP10** oil and tighten to the recommended tightening torque.

When replacing a pipe, add **10 ml** of **SP10** oil or if a pipe is split (rapid leakage), add **100 ml** and change the dehydrating bottle.

The temperature sensor supplied by the Parts Department is supplied with its wiring assembly; it is therefore necessary to replace the wiring assembly.

REMOVAL

Disconnect the battery.

Remove :

- the windscreen wiper arms,
- the external air intake grilles,
- the earth wiring braid on the bulkhead.

Disconnect the electrical wiring and remove the clips on the evaporator assembly.

Remove the assembly.

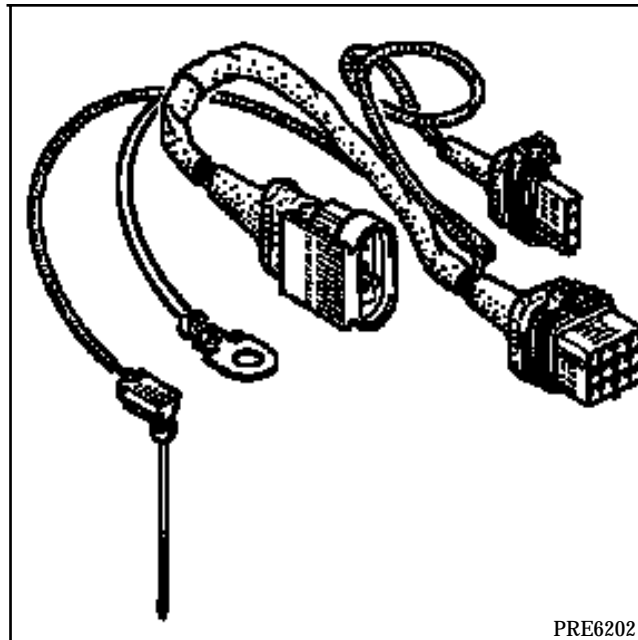

REFITTING

Refit in reverse order to removal.

The evaporator assembly must be removed in order to gain access to the recycling motor (refer to the section on removing the evaporator).

REMOVAL

Disconnect the recycling motor connections.

Remove :

- the two bolts securing the recycling motor,
- the clips from the evaporator assembly, unclip the evaporator assembly, partially open it and remove the recycling motor (the recycling motor supplied by the Parts Department is supplied with the flap).

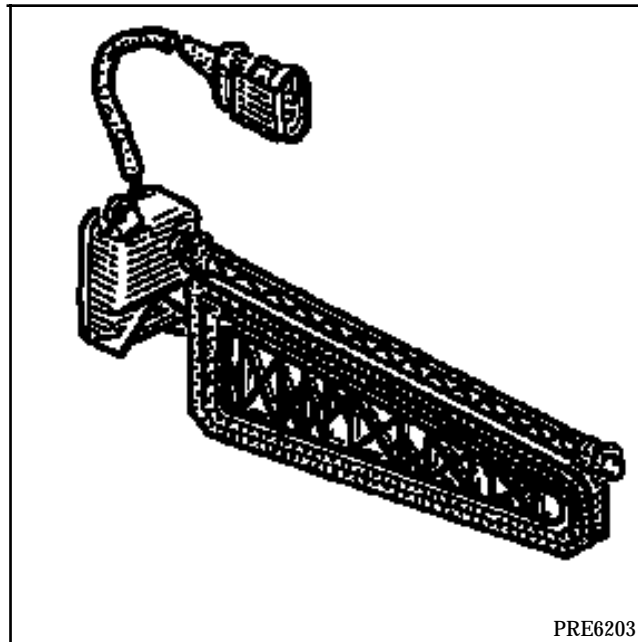

REFITTING

Refit in reverse order to removal.

TIGHTENING TORQUES (in daN.m)	
Flange bolts for dehydrating bottle pipes	1

REMOVAL

Drain the **R134a** refrigerant circuit using the charging station.

Disconnect the battery.

Remove :

- the flange bolt for the dehydrating bottle pipes and fit the plugs in the holes,
- the support bracket for the dehydrating bottle on the radiator, bolts (A).

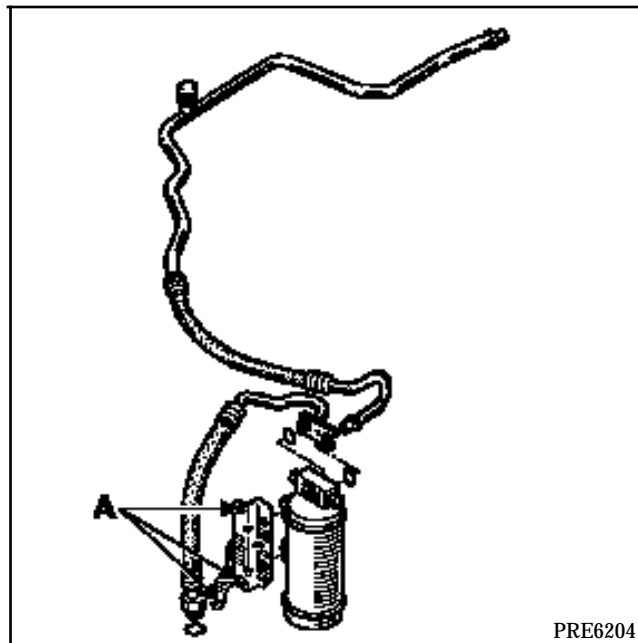

REFITTING

Refit in reverse order to removal. Refit and oil the joints using **SP10** oil and tighten to the recommended tightening torque.

When replacing the dehydrating bottle, add **15 ml** of **SP10** oil.

TIGHTENING TORQUES (in daN.m)	
Pressostat	1

REMOVAL

Drain the **R134a** refrigerant circuit using the charging station.

Disconnect :

- the battery,
- the connectors and remove the three-way pressostat.

Fit a plug in the hole for the condenser.

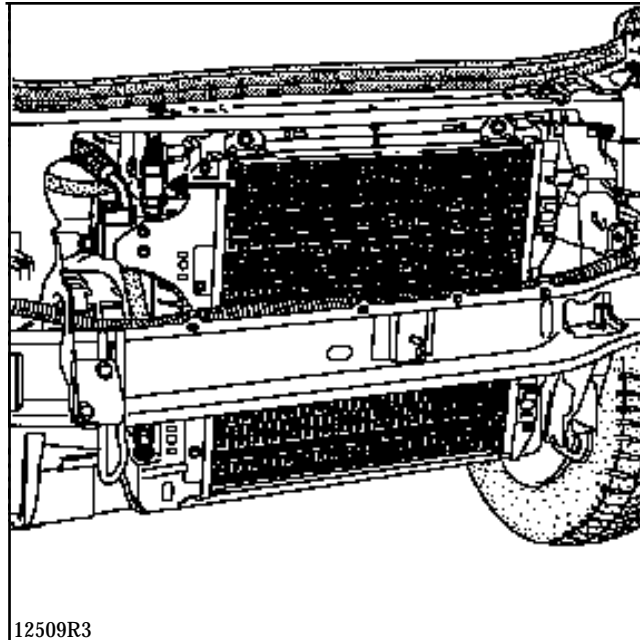

REFITTING

Refit in reverse order to removal and tighten to the recommended tightening torque.

REMOVAL

Disconnect the battery.

Remove :

- the windscreen wiper arms,
- the external air intake grilles.

Disconnect the connectors.

Remove the two bolts and disengage the electronic unit.

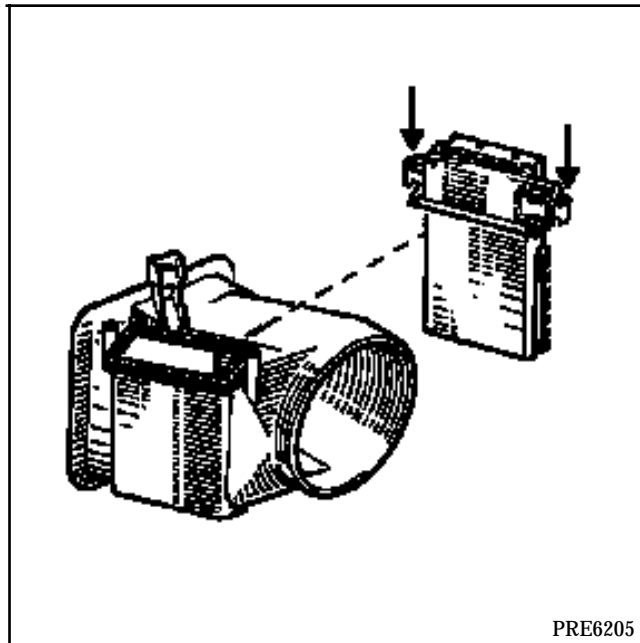

REFITTING

Refit in reverse order to removal.

AIR CONDITIONING

Passenger compartment fan

62

The evaporator must be removed in order to gain access to the passenger compartment fan (see section on removing the evaporator).

REMOVAL

Remove the two mounting bolts and release the fan by turning it in the direction of the arrow.

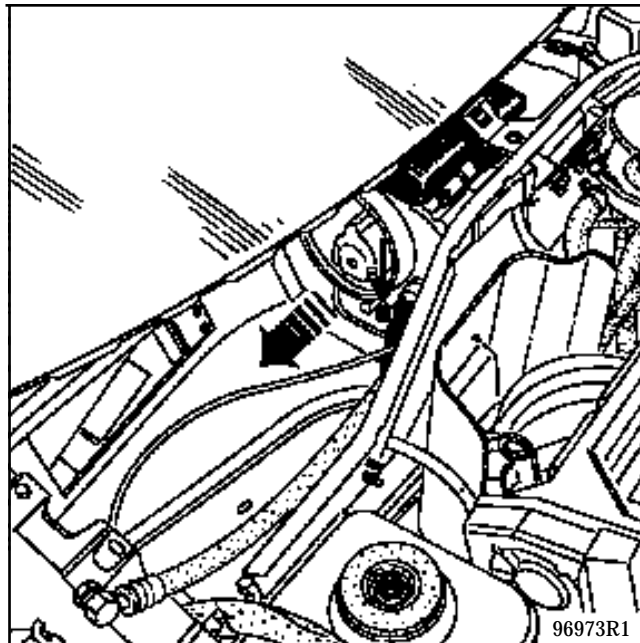

REFITTING

Refit in reverse order to removal.